



# Standard Practice for Preparation and Use of Bent-Beam Stress-Corrosion Test Specimens<sup>1</sup>

This standard is issued under the fixed designation G39; the number immediately following the designation indicates the year of original adoption or, in the case of revision, the year of last revision. A number in parentheses indicates the year of last reapproval. A superscript epsilon ( $\epsilon$ ) indicates an editorial change since the last revision or reapproval.

## 1. Scope

1.1 This practice covers procedures for designing, preparing, and using bent-beam stress-corrosion specimens.

1.2 Different specimen configurations are given for use with different product forms, such as sheet or plate. This practice is applicable to specimens of any metal that are stressed to levels less than the elastic limit of the material, and therefore, the applied stress can be accurately calculated or measured (see **Note 1**). Stress calculations by this practice are not applicable to plastically stressed specimens.

**NOTE 1**—It is the nature of these practices that only the applied stress can be calculated. Since stress-corrosion cracking is a function of the total stress, for critical applications and proper interpretation of results, the residual stress (before applying external stress) or the total elastic stress (after applying external stress) should be determined by appropriate nondestructive methods, such as X-ray diffraction (**1**).<sup>2</sup>

1.3 Test procedures are given for stress-corrosion testing by exposure to gaseous and liquid environments.

1.4 The bent-beam test is best suited for flat product forms, such as sheet, strip, and plate. For plate material the bent-beam specimen is more difficult to use because more rugged specimen holders must be built to accommodate the specimens. A double-beam modification of a four-point loaded specimen to utilize heavier materials is described in **10.5**.

1.5 The exposure of specimens in a corrosive environment is treated only briefly since other practices deal with this aspect, for example, Specification **D1141**, and Practices **G30**, **G36**, **G44**, **G50**, and **G85**. The experimenter is referred to ASTM Special Technical Publication 425 (**2**).

1.6 The bent-beam practice generally constitutes a constant strain (deflection) test. Once cracking has initiated, the state of stress at the tip of the crack as well as in uncracked areas has changed, and therefore, the known or calculated stress or strain

values discussed in this practice apply only to the state of stress existing before initiation of cracks.

1.7 The values stated in SI units are to be regarded as standard. The inch-pound values in parentheses are provided for information.

1.8 *This standard does not purport to address all of the safety concerns, if any, associated with its use. It is the responsibility of the user of this standard to establish appropriate safety and health practices and determine the applicability of regulatory limitations prior to use.* (For more specific safety hazard information see Section **7** and **12.1**.)

## 2. Referenced Documents

### 2.1 ASTM Standards:<sup>3</sup>

**D1141** Practice for the Preparation of Substitute Ocean Water

**G30** Practice for Making and Using U-Bend Stress-Corrosion Test Specimens

**G36** Practice for Evaluating Stress-Corrosion-Cracking Resistance of Metals and Alloys in a Boiling Magnesium Chloride Solution

**G44** Practice for Exposure of Metals and Alloys by Alternate Immersion in Neutral 3.5 % Sodium Chloride Solution

**G50** Practice for Conducting Atmospheric Corrosion Tests on Metals

**G85** Practice for Modified Salt Spray (Fog) Testing

### 2.2 NACE Documents:<sup>4</sup>

**NACE TM0177-96** Laboratory Testing of Metals for Resistance to Specific Forms of Environmental Cracking in H<sub>2</sub>S Environments

## 3. Terminology

### 3.1 Definitions of Terms Specific to This Standard:

3.1.1 *cracking time*—the time elapsed from the inception of test until the appearance of cracking.

<sup>1</sup> This practice is under the jurisdiction of ASTM Committee **G01** on Corrosion of Metals and is the direct responsibility of Subcommittee **G01.06** on Environmentally Assisted Cracking.

Current edition approved May 1, 2016. Published May 2016. Originally approved in 1973. Last previous edition approved in 2011 as G39 – 99 (2011). DOI: 10.1520/G0039-99R16.

<sup>2</sup> The boldface numbers in parentheses refer to a list of references at the end of this standard.

<sup>3</sup> For referenced ASTM standards, visit the ASTM website, [www.astm.org](http://www.astm.org), or contact ASTM Customer Service at [service@astm.org](mailto:service@astm.org). For *Annual Book of ASTM Standards* volume information, refer to the standard's Document Summary page on the ASTM website.

<sup>4</sup> Available from NACE International (NACE), 1440 South Creek Dr., Houston, TX 77084-4906, <http://www.nace.org>.

3.1.1.1 *Discussion*—The test begins when the stress is applied and the stressed specimen is exposed to the corrosive environment, whichever occurs later.

3.1.1.2 *Discussion*—The specimen is considered to have failed when cracks are detected. Presence of cracks can be determined with or without optical, mechanical, or electronic aids. However, for meaningful interpretation, comparisons should be made only among tests employing crack detection methods of equivalent sensitivity.

3.1.2 *stress-corrosion cracking*—a cracking process requiring the simultaneous action of a corrodent and sustained tensile stress. This excludes corrosion-reduced sections that fail by fast fracture. It also excludes intercrystalline or transcrystalline corrosion which can disintegrate an alloy without either applied or residual stress.

#### 4. Summary of Practice

4.1 This practice involves the quantitative stressing of a beam specimen by application of a bending stress. The applied stress is determined from the size of the specimen and the bending deflection. The stressed specimens then are exposed to the test environment and the time required for cracks to develop is determined. This cracking time is used as a measure of the stress-corrosion resistance of the material in the test environment at the stress level utilized.

#### 5. Significance and Use

5.1 The bent-beam specimen is designed for determining the stress-corrosion behavior of alloy sheets and plates in a variety of environments. The bent-beam specimens are designed for testing at stress levels below the elastic limit of the alloy. For testing in the plastic range, U-bend specimens should be employed (see Practice G30). Although it is possible to stress bent-beam specimens into the plastic range, the stress level cannot be calculated for plastically-stressed three- and four-point loaded specimens as well as the double-beam specimens. Therefore, the use of bent-beam specimens in the plastic range is not recommended for general use.

#### 6. Apparatus

6.1 *Specimen Holders*—Bent-beam specimens require a specimen holder for each specimen, designed to retain the applied stress on the specimen. Typical specimen holder configurations are shown schematically in Fig. 1.

NOTE 2—The double-beam specimen, more fully described in 10.5, is self-contained and does not require a holder.

NOTE 3—Specimen holders can be modified from the constant deformation type shown in Fig. 1 to give a constant-load type of stressing. For instance, the loading bolt can be supplanted by a spring or deadweight arrangement to change the mode of loading.

6.1.1 The holder shall be made of a material that would withstand the influence of the environment without deterioration or change in shape.

NOTE 4—It should be recognized that many plastics tend to creep when subjected to sustained loads. If specimen holders or insulators are made of such materials, the applied stress on the specimen may change appreciably with time. By proper choice of holder and insulator materials, however, many plastics can be used, especially in short-time tests.

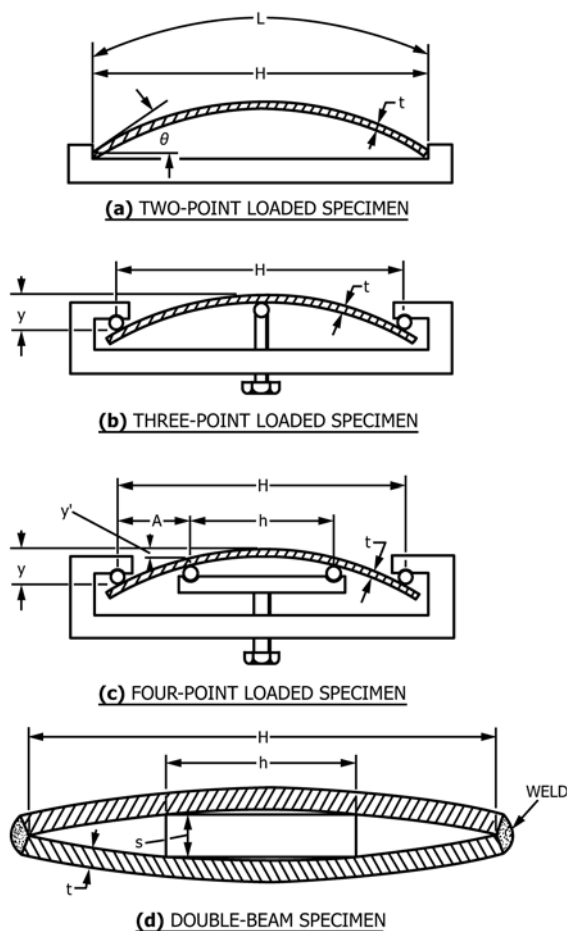

FIG. 1 Schematic Specimen and Holder Configurations

6.1.2 When the stress-corrosion test is conducted by immersion in an electrolyte, galvanic action between specimen and holder (or spacer) shall be prevented (see Note 5). This is accomplished by (1) making the holder of the same material as the individual specimens, (2) inserting electrically insulating materials between specimen and holder at all points of contact (see Note 4), (3) making the entire holder out of a nonmetallic material (see Note 4), or (4) coating the holder with an electrically nonconducting coating that effectively prevents contact between holder and electrolyte.

6.1.3 Crevice corrosion may occur in an electrolyte at contact points between specimen and holder (or spacer). In these instances the critical areas should be packed with a hydrophobic filler (such as grease or wax).

NOTE 5—In atmospheres (gas) galvanic action between specimen and holder either does not exist or is confined to a very small area as experienced in outdoor exposure tests.

6.2 *Stressing Jigs*—Three-point and four-point loaded specimen holders, Fig. 1(b and c), contain a stressing feature in the form of a loading screw. To stress two-point loaded specimens (Fig. 1(a)), a separate stressing jig shall be used. A convenient stressing jig is shown in Fig. 2.

NOTE 6—The double-beam specimen, described in 10.5, requires a mechanical or hydraulic stressing frame (a universal tension testing machine can also be used) as well as welding equipment.



FIG. 2 Stressing Jig and Two-Point Loaded Specimen with Holder (approximately ¼ actual size)

6.3 *Deflection Gauges*—Deflection of specimens is determined by separate gages or by gages incorporated in a loading apparatus as shown in Fig. 3. In designing a deflection gage to suit individual circumstances care must be taken to reference the deflection to the proper support distance as defined in 10.2 – 10.5.

## 7. Hazards

7.1 Bent-beam specimens made from high-strength materials may exhibit high rates of crack propagation and a specimen may splinter into several pieces. Due to high stresses in a specimen, these pieces may leave the specimen at high velocity and can be dangerous. Personnel installing and examining specimens should be cognizant of this possibility and be protected against injury.

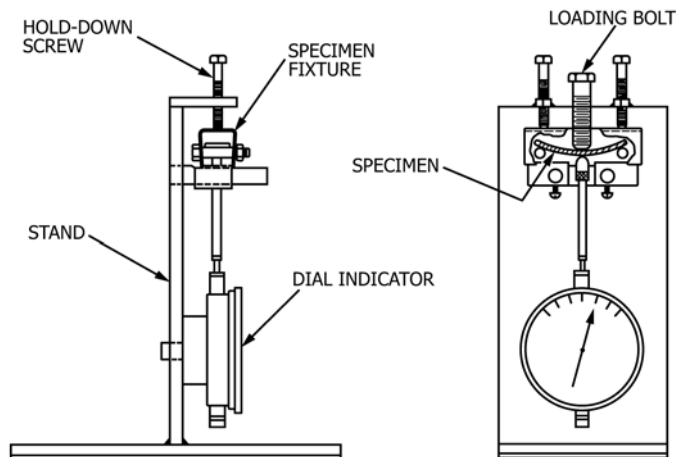

FIG. 3 Specimen Loading Apparatus for Three-Point Loaded Beam Specimens with Integral Deflection Gage

## 8. Sampling

8.1 Test specimens shall be selected so that they represent the material to be tested. In simulating a service condition, the direction of load application in the specimen shall represent the anticipated loading direction in service with respect to processing conditions, for example, rolling direction.

8.2 Paragraphs 9.4 and 9.5 deal specifically with specimen selection as related to the original material surface.

## 9. Test Specimen

9.1 The bent-beam, stress-corrosion specimens shall be flat strips of metal of uniform, rectangular cross section, and uniform thickness.

9.2 The identification of individual specimens should be permanently inscribed at each end of the specimen because this is the area of lowest stress and cracking is not expected to be initiated by the identification markings. If stenciling is used for identification, this shall be done only on softened material before any hardening heat treatments to prevent cracking in the stenciled area. Care must be taken to prevent the identification from being obliterated by corrosion.

9.3 Mechanical properties should be determined on the same heat-treatment lot from which stress-corrosion specimens are obtained.

9.4 The specimens can be cut from sheet or plate in such a fashion that the original material surface is retained. This procedure is recommended when it is desired to include the effect of surface condition in the test.

9.5 If, however, it is desired that surface conditions should not influence the test results of several materials with different surface conditions, the surfaces of all specimens must be prepared in the same way. It is recommended that grinding or machining to a surface finish of at least  $0.7 \mu\text{m}$  ( $30 \mu\text{in.}$ ) and to a depth of at least  $0.25 \text{ mm}$  ( $0.01 \text{ in.}$ ) be utilized for surface preparation. It is desirable to remove the required amount of metal in several steps by alternately grinding opposite surfaces. This practice minimizes warpage due to residual stresses caused by machining. All edges should be similarly ground or machined to remove cold-worked material from previous shearing. Chemical or electrochemical treatments that produce hydrogen on the specimen surface must not be used on materials that may be subject to embrittlement by hydrogen or that react with hydrogen to form a hydride.

9.6 Immediately before stressing, the specimens should be degreased and cleaned to remove contamination that occurred during specimen preparation. Only chemicals appropriate for the given metal or alloy should be used. Care must be exercised not to contaminate cleaned specimens. Also, it is suggested that specimens be examined for cracks before exposure to the test environment.

## 10. Stress Calculations

10.1 The equations given in this section are valid only for stresses below the elastic limit of the material. At stresses above the elastic limit, but below the engineering yield strength ( $0.2 \%$  offset) only a small error results from use of the